



Bar Panel

SECTIONAL OVERHEAD DOOR

Recommended Specifications

The sectional overhead "Pirie Bar Panel" shall be manufactured to comply with Pirie Enterprises Pty Ltd quality assurance programme. External framing and vertical muntins to be 50.8 x 50.8 extruded aluminium box section. Frame, muntins and end styles be fully welded and ground flush on face and back of panel. Vertical muntins spacing not greater than 1500mm apart. Horizontal bars to be extruded aluminium tube and spaced no greater than 110mm apart. Panel height to be no higher than 650mm. Reinforcing angle to be fitted to top of each panel. Top panel to have extra muntin in centre for operator drive arm. Panels to be powder coat finish. Hinges will be bolt through fixing, self tapping screw on centre muntins. Two rubber stoppers fitted to the bottom of the bottom panel equally spaced from each end.

The door shall consist of panels hinged together to negotiate the curve of the track and a fixed matching head panel if required. The number of panels in each door shall be as recommended by the manufacturer. Each panel shall be fitted with rollers running in the side tracks, hardware and hinges hangers shall be made from galvanised or zincannealed steel. Hinges, hangers shall be fabricated from 2mm thick sheet. Tracks shall be fabricated from 1.6mm sheet and shall be curved where necessary to required radius and mounted on mild steel brackets fixed to the building structure by approved means. Horizontal runs shall be reinforced with mild steel angles. Springs shall be helical wound torsion springs mounted on a 25mm torsion bar with alloy cable drums attached. Galvanized lifting cables to be used. Engineers wind load specification 50mps for doors up to 20 sq. metres.

FOR FURTHER INFORMATION CONTACT MANUFACTURERS

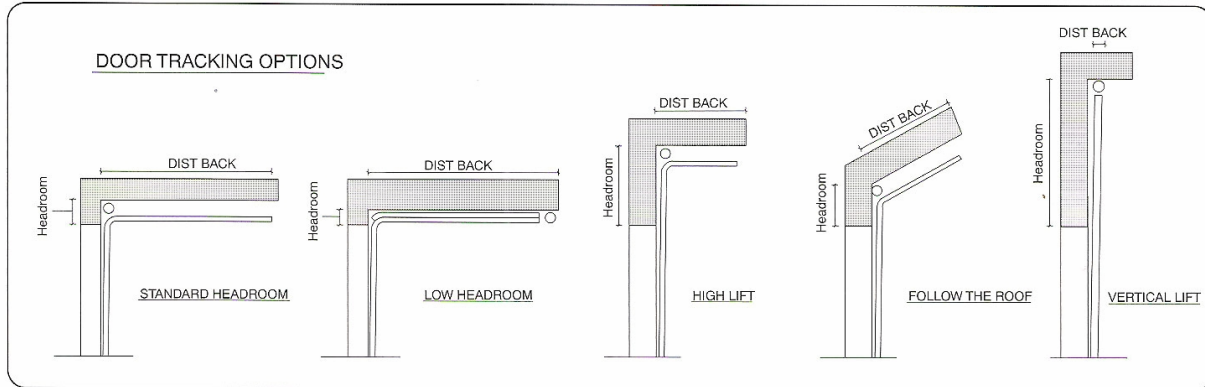
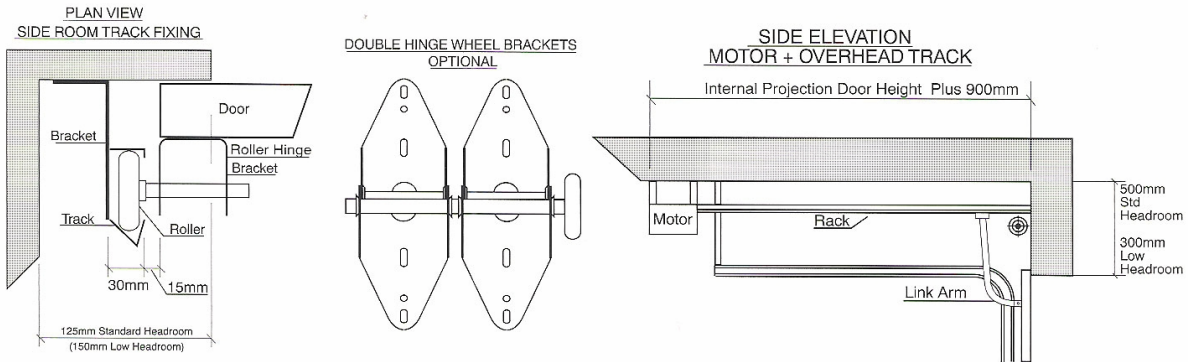

Other products available: Manufacturers of Industrial, Commercial, Domestic Automatic Doors and Gates • Structural Aluminium
• Architecturally designed Sectional Overhead Doors • Aluminium Louvres & Vents • Glass bricks Pre Fab or Fire Rated • Fire Doors • Parking Systems



Est. 1952

Showroom: 22 Industrial Avenue, Southport 4215
 Phone: 07 5539 6644
 Fax: 07 5539 6988
 A.B.N. 16 009 731 113

AGENT:-